



WAM®



INCLINED METERING VALVE
DOSIERSCHIEBER
VANNE DOSEUSE INCLINEE
VALVOLA DOSATRICE INCLINATA

VDI

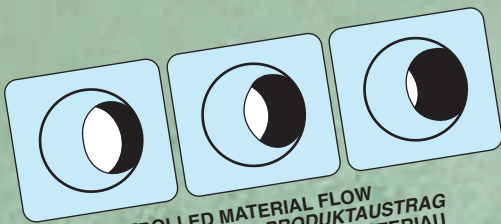

- CONTROLLED MATERIAL FLOW
- KONTROLLIERTER PRODUKTAUSTRAG
- DESCENTE CONTROLLEE DU MATERIAU
- DISCESA CONTROLLATA DEL MATERIALE

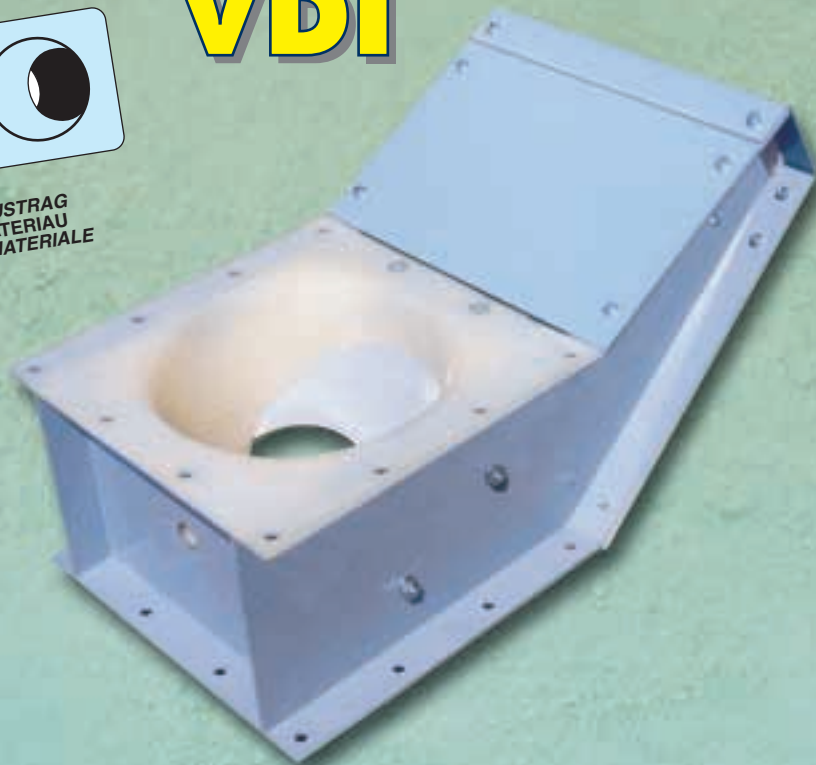

The VDI Valve is a flow intercepting device with special feeding properties which are mainly based on the tapering valve body ending in an elliptical outlet cross section. This guarantees a "controlled" material flow for most powders and granular materials.

Der VDI Schieber ist ein Absperrorgan mit besonderen Austrage- und Dosiereigenschaften. Diese Eigenschaften beruhen hauptsächlich auf dem sich kegelstumpfförmig zur Ellipse verjüngenden Schiebergehäusequerschnitt, der einen "kontrollierten" Materialfluß der Mehrzahl aller Schüttgüter gewährleistet.

La vanne VDI est un organe de régulation de débit avec des caractéristiques d'extraction et de dosage. Ses caractéristiques ont, principalement, leur origine dans la configuration elliptique des surfaces intérieures de la vanne, en mesure de garantir la descente "contrôlée" de la plupart des produits.

La valvola VDI è un organo di intercettazione con particolari caratteristiche di estrazione e dosaggio. Tali caratteristiche sono dovute principalmente alla conformazione ellittica interna delle superfici della valvola in grado di garantire la discesa "controllata" della maggior parte dei prodotti.

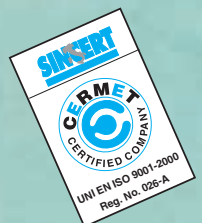

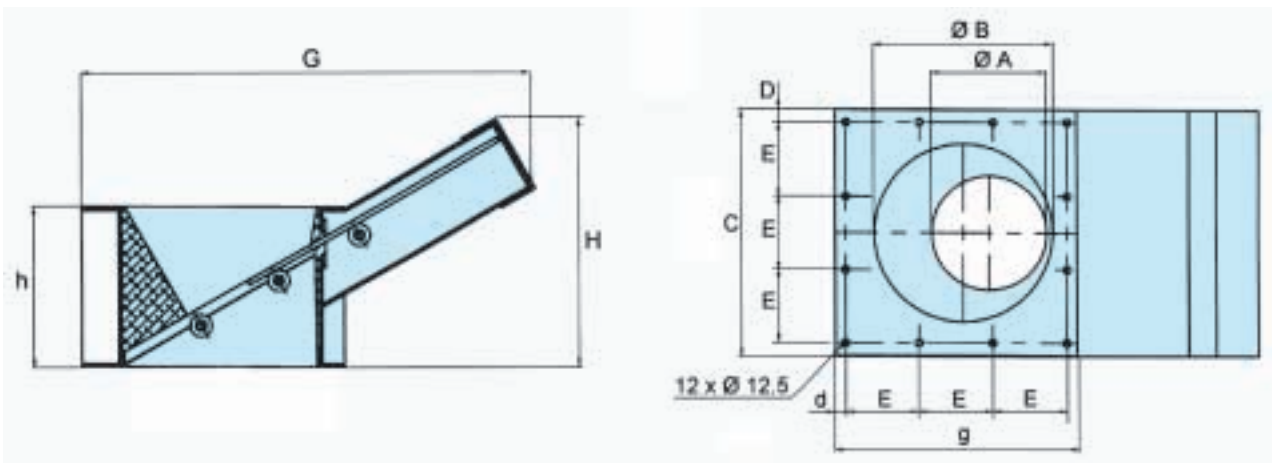

Type	Ø A	Ø B	C	D	d	E	Ø F	Bolts - Schrauben Vis - Viti	G	g	H	h	kg
VDI0150..	137	225	311	15.5	15.5	93.3	12.5	M 10	593	311	358	233	22
VDI0250..	200	310	431	23	19	128.3	12.5	M 10	780	422	392	258	38
VDI0300..	250	360	481	18	18	89	12.5	M 10	832	481	462	296	67

Dimensions in mm

- 1 mild steel / Normalstahl / acier normal / acciaio al carbonio
- 2 stainless steel 304 / Edelstahl 1.4301 / acier inox 304 / AISI 304



HAND WHEEL COUPLING - KOMBINATION MIT HANDRAD
ACCOUPLLEMENT DE L'ACTIONNEUR MANUEL - ABBINAMENTI DI ATTUATORE MANUALE

- VDI 0150.. -CMG0200 I.
- VDI 0250.. -CMG0250 I.
- VDI 0300.. -CMG0300 I.



PNEUMATIC ACTUATOR COUPLING - KOMBINATION MIT PNEUMATIKANTRIEB
ACCOUPLLEMENT DE COMMANDE ELECTROPNEUMATIQUE - ABBINAMENTO DI COMANDO ELETTOPNEUMATICO

- VDI 0150.. — P.N. CYL.Ø 63 x 200 — KCP 063 1525 - V5V80 - LSM6
- VDI 0250.. — P.N. CYL.Ø 80 x 250 — KCP 080 1530 - V5V80 - LSM6
- VDI 0300.. — P.N. CYL.Ø 80 x 300 — KCP 080 1530 - V5V80 - LSM6

★

*Series BOB WAM

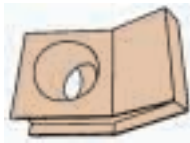

- ALUMINIUM BODY
- ALU-GEHÄUSE
- CORPS EN ALUMINIUM
- CAMICIA IN ALLUMINIO
- ALTERNATING CURRENT
- WECHSELSTROM
- COURANT ALTERNATIF
- CORRENTE ALTERNATA
- DIRECT CURRENT
- GLEICHSTROM
- COUANT CONTINU
- CORRENTE CONTINUA

Non WAM - Fremdfabrikat
 Hors fourniture WAM
 Non fornitura WAM (Cons. Uff. Comm.)



GEAR MOTOR COUPLING - KOMBINATION MIT GETRIEBEMOTOR
ACCOUPLLEMENT DE AVEC MOTOREDUCTEUR - ABBINAMENTI DI ATTUATORE CON MOTORIDUTTORE

UNDER LIGHT LOAD
 UNTER LEICHTLAST
 SOUS FAIBLE CHARGE
 SOTTO PICCOLO BATTENTE

UNDER HEAVY LOAD
 UNTER SCHWERLAST
 SOUS FORTE CHARGE
 SOTTO GRANDE BATTENTE

- VDI 0150.. — CRG010A200 I. - CRG010B200 I.
 - VDI 0250.. — CRG010A250 I. - CRG010B250 I.
 - VDI 0300.. — CRG010A300 I. - CRG010B300 I.
- LSM6

N.B.: Rights reserved to modify technical specifications.

N.B.: Angaben ohne Gewähr. Änderungen können ohne Vorankündigung vorgenommen werden.

N.B.: Toutes données portées dans le présent catalogue n'engagent pas le fabricant. Elles peuvent être modifiées à tout moment.

N.B.: Tutti i dati riportati nel presente catalogo non sono impegnativi e possono subire variazioni in qualsiasi momento.

WAM. 3030

10/03



PROORGANIKA S.A.
 ul. Krasińskiego 69
 01-755 Warszawa

+ 48 / 22 / 32 60 350
 fax + 48 / 22 / 32 60 351
 e-mail proorganika@proorganika.com.pl
 internet www.proorganika.com.pl