

## Special Valves

In addition to its standard range of rotary valves and blowing seals, Rota Val Ltd. offers 'special' valves, often in close collaboration with customers, to suit almost every application, no matter how difficult the material or extreme the conditions. Examples of 'specials' are shown below.



DESIGNS TO MEET CLIENTS' SPECIFIC REQUIREMENTS



VALVES FOR HIGH-DIFFERENTIAL PRESSURES



TANDEM VALVE FOR NON-SHEARABLE PRODUCTS



SPECIAL DESIGN FOR TOBACCO

# ROTAVAL

Keeping the World's Industries Solidly in control



## Rotary Valves and Blowing Seals

Inlet sizes 50mm-700mm  
Capacities up to 230m<sup>3</sup>/hour

# ROTAVAL

Przedstawicielstwo w Polsce - PROORGANIKA S.A.

01-755 Warszawa, ul. Krasińskiego 69

Tel: +48 (022) 3260350, Fax: +48 (022) 3260351

Email: [proorganika@proorganika.com.pl](mailto:proorganika@proorganika.com.pl), [www.proorganika.com.pl](http://www.proorganika.com.pl)

RVB 60 Issue 6 2000



Established in 1970, Rota Val has grown to become a highly respected name in the design and manufacture of top-quality rotary and diverter valves - with customers in more than 40 countries. We supply valves to handle most materials - from abrasive minerals to baby food, explosive chemicals to clinical pharmaceuticals - in operating conditions ranging from -100°C to +900°C and often under adverse pressures. Whatever your bulk handling requirements, Rota Val will almost certainly have the answers, either within our standard range or by designing for your specific application.



750mm Heavy-duty Rotary Valve capable of 230m<sup>3</sup>/hr



50mm Easy-Clean stainless steel Rotary Valve with variable throughput 0.7-4.8 ltrs/m.

 **HD**  
Heavy-duty general purpose Rotary Valve, with a wide range of options.

## HD Rotary Valves

12 sizes to give capacities up to 230m<sup>3</sup>/hr

Developed to meet the specific needs of modern bulk handling systems, the HD series rotary valves are designed and constructed to ensure high sealing and feeding efficiency with maximum durability. A wide range of interchangeable components and design features ensure that a suitable unit can be matched to the requirements of almost any application. The HD series valve is the 'design hub' around which all Rota Val's rotary valves are based, a feature which results in competitive prices without compromising performance.

## BS Blowing Seals

7 sizes to give capacities up to 145m<sup>3</sup>/hr

For feeding a wide range of powdered solids direct into a pneumatic conveying pipeline. High overall efficiency makes these valves particularly suitable for handling low density powders which are easily fluidised. Identical in design and construction to the HD series except that the body and end covers have an integrally-cast entrainment trough for direct installation into the conveying pipeline. Semi-direct purge design enables efficient purging of rotor pockets with minimal interference to air flow by the rotor vanes.



 **BS**  
Heavy-duty general purpose Rotary Blowing Seal.

## HDER Rotary Valves BSER Blowing Seals

7 sizes to give capacities up to 24m<sup>3</sup>/hr

Recommended when frequent internal cleaning of the valve is necessary. Dismantling and re-assembly may be carried out by plant operators since no special tools or specific fitting skills are required.

Various standards of finish are available to suit most food and pharmaceutical applications; however, for the most stringent hygienic requirements, consider the 'FCT' Fast-Clean Rotary Valve.



 **FCT**  
Fast-Clean Rotary Valve - eliminates manual lifting (under primary cleaning operations). Features available to meet stringent hygiene requirements. Explosion-proof and flame-containment certified.

See separate brochure for additional information.

## EHD Rotary Valves EBS Blowing Seals

7 sizes to give capacities up to 115m<sup>3</sup>/hr

For use where solids handled and operating conditions combine to cause abrasive erosion within the valve. Higher unit costs are more than outweighed by the greatly increased operating life and ease of 'on-site' component replacement.

Both the EHD and EBS valves have been well-proven over many years and are widely used in discharging under adverse pressure conditions such materials as cement, PFA, granite dust, silica sand, mineral powders, etc. For the more abrasive of these products an EHD valve with line entrainment adaptor should be considered.

**NOTE**  
Service life of these valves will vary according to the service conditions prevailing. Selection must be undertaken with care and system conditions where possible adopted to ensure maximum service life. Our Technical Department will be pleased to make recommendations as appropriate.



 **HDER**  
Rotary Valve (easy-clean option) with fully demountable, deep-scalloped, sealed-end rotor for hygienic applications.



 **EHD**  
High Performance Rotary Valve for abrasive products and high pressures.

# Valve selection

FOR GUIDANCE ONLY. EXACT THROUGHPUT CAN BE CALCULATED USING THE FORMULA OPPOSITE

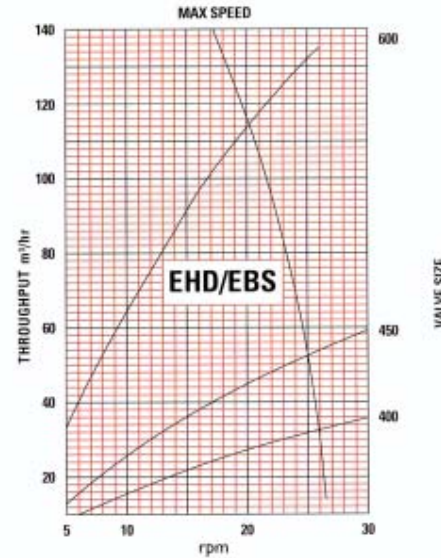
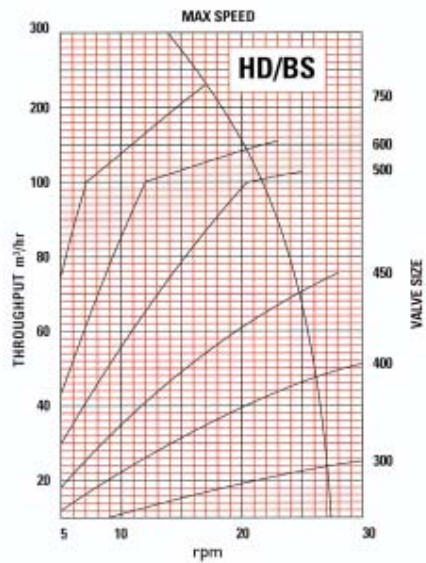
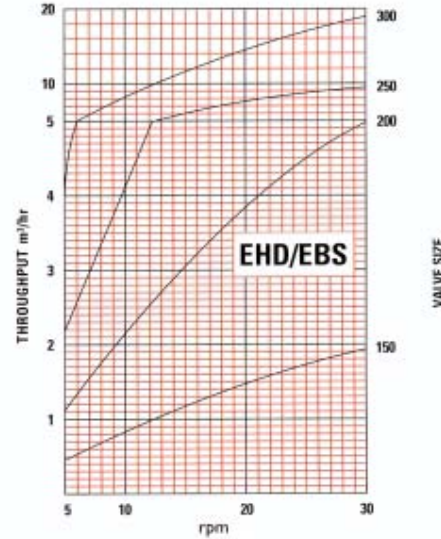
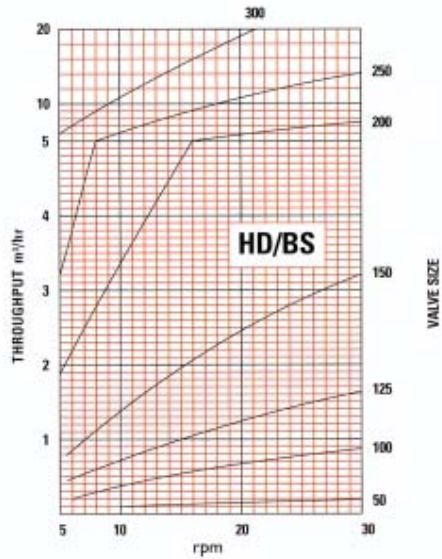

Valve size	Capacity at 100% Full m³/hr/rpm				
	Open fixed vane	Open vane Repl blade	Closed fixed vane	Closed vane Repl blade	
50	0.011				
100	0.042		0.037		} HD
125	0.078		0.070		
150	0.153	0.143	0.140	0.135	
200	0.370	0.349	0.332	0.323	} HD & BS
250	0.676	0.621	0.622	0.604	
300	1.199	1.114	1.109	1.088	
400	2.459	2.210	2.100	2.059	
450	4.044	3.707	3.731	3.678	
500	6.528	6.413	6.056	5.995	
600	8 vane 9.691 10 vane 9.463	9.496 9.217	8.623 8.420	8.517 8.287	
750	8 vane 17.869 10 vane 17.529		16.968	16.832 16.475	} HD

The following formula may be used to determine the valve size using the above chart

$$\text{Valve speed (rpm)} = \frac{\text{throughput (kg/hr)}}{\text{loose bulk density of product (kg/m}^3\text{) } \times \text{ capacity (m}^3\text{/hr/rpm) } \times \text{ filling efficiency}}$$

The assessment of filling efficiencies is a matter of judgement based on the information available. An indication can be obtained from the graph below. Our technical staff will be pleased to advise as required.

## Filling Efficiencies

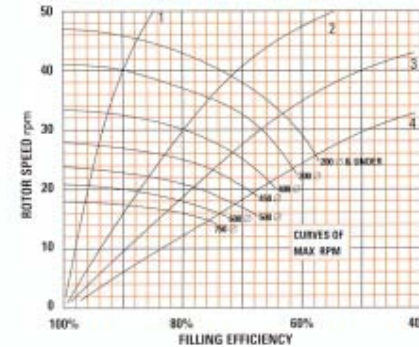

The graph indicates anticipated filling efficiency when handling bulk solids as indicated below and when operating against a positive pressure differential of around 0.5kg/cm² (0.5 barg).

**Curve 1** Very free-flowing solids either aided or unaffected by leakage air, e.g. sand, some metal oxides, dense plastic granules, etc.

**Curve 2** Free-flowing solids often aided by leakage air due to fluidisation, e.g. cement, PFA, lime, etc

**Curve 3** Sluggish and light materials, usually where leakage air tends to oppose flow, e.g. plastic powder, resin powder, milk powder, etc.

**Curve 4** Sluggish and light materials, either where leakage air opposes solids flow or where bulk density is greatly reduced by aeration, e.g. most light fibrous materials, flour, carbon black, cork granules, etc.

### Note:

Filling efficiencies for groups 3 and 4 are often greatly improved when the valve is operating under very low, or negative, pressure conditions. Also filling efficiencies for these groups can often be improved by venting when discharging under high pressure conditions.

## Leakage Factors

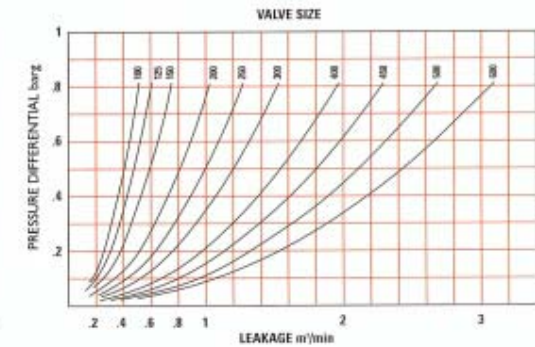

### Note:

The leakage factors indicated above are for guidance only and represent those obtained by the various units operating without solids present.

When discharging material, leakage through the valve is reduced, due to the blocking of some of the running clearances by the product. This can vary from as little as 3% for granular materials to as high as 90% for resin and plastic powders.

Of necessity, some materials and system conditions will require greater running clearances in the valve and leakage rates will increase proportionately.

Leakage is related to the square root of the pressure differential across the valve rotor. The pressure differential, and therefore the leakage, will usually be reduced if there is a working head of material above the valve, and where there is no venting.

For practical purposes, displaced leakage caused by rotor speed is not significant and can be ignored.

# HD and EHD

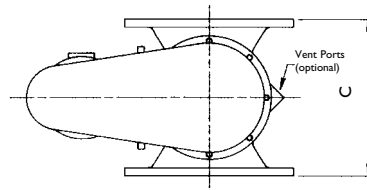
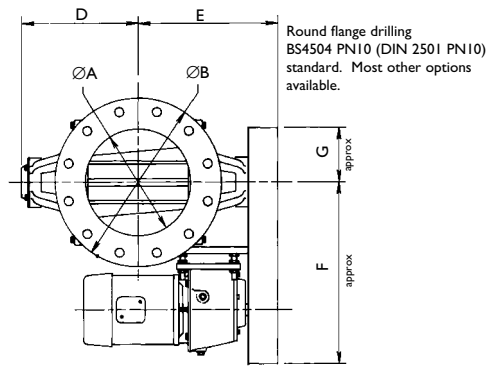

# BS and EBS

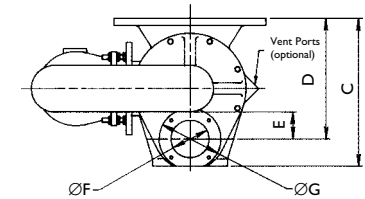
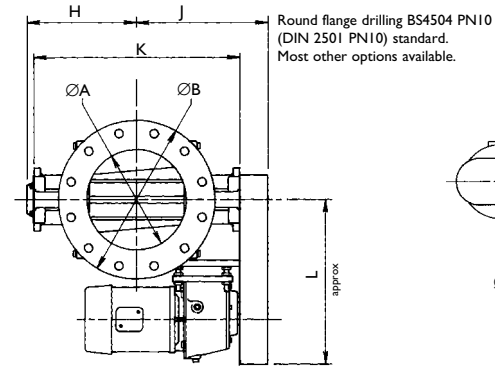

# HDER

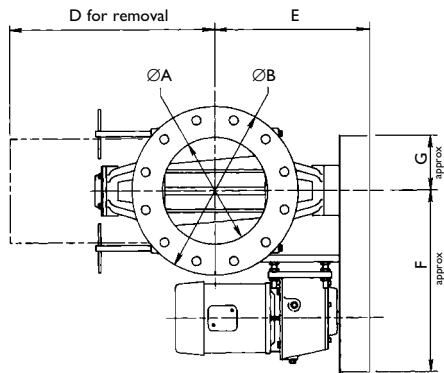

Size	A	B
125	125	225
150	152	254
200	200	305
250	253	355
300	303	410
400	380	510
450	452	580
500	490	700
600	550	700
750	700	880

Square flange option - all types

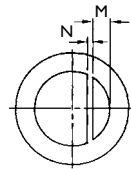
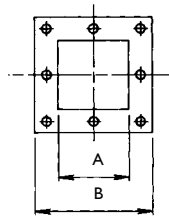

Inlet vane divider (optional) - all types

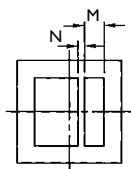

Valve Type	Size	HD			HDER			EHD			Drive kW	Approx Wt kg						
		ØA	ØB	C	D	E	D	E	D	E		F	G	M	N			
HD HDER	50	50	165	140	133	188	385	213	-	-	368	68	-	-	.37	35	35	-
HD HDER	100	103	229	170	161	216	470	241	-	-	368	68	-	-	.37	40	40	-
HD HDER	125	127	254	197	184	236	508	264	-	-	388	68	31	12	.37	48	50	-
HD HDER EHD	150	155	280	250	194	247	540	275	194	247	415	95	37	12	.37	55	55	66
HD HDER EHD	200	206	343	325	242	293	580	325	260	318	395	95	50	12	.37	100	100	114
HD HDER EHD	250	257	406	380	289	347	690	383	291	347	505	132	62	12	.75	150	150	185
HD HDER EHD	300	310	483	457	314	372	765	408	317	373	505	132	75	12	.75	190	190	235
HD EHD	400	380	597	560	375	433	-	-	373	443	640	132	95	16	1.5	380	-	450
HD EHD	450	450	640	640	407	465	-	-	405	475	640	132	112	16	1.5	570	-	680
HD	500	500	698	800	500	584	-	-	-	-	825	177	130	16	2.2	750	-	-
HD EHD	600	550	820	800	558	621	-	-	558	626	825	177	150	20	3.0	910	-	1100
HD	750	Square only	1020	624	683	-	-	-	-	-	1035	257	187	20	4.0	1420	-	-

Materials of construction and/or alternative valve features may alter some of the stated dimensions. This information is therefore to be used for guidance only. Use certified drawings for planning-in. These will be issued against an order. These valves must not be considered as load-bearing without prior consultation.

Valve Type	Size	BS			EBS			BS			EBS			Drive kW	Approx Wt kg						
		ØA	ØB	C	D	D	E	ØF	ØG	H	J	K	H		J	K	L	M	N		
BS EBS	150	155	280	256	217	217	45	57	100	194	238	348	194	247	348	375	37	12	.37	55	66
BS EBS	200	206	343	365	295	302	64	76	127	242	286	439	260	318	483	395	50	12	.37	100	114
BS EBS	250	257	406	400	326	326	72	102	165	289	347	532	291	347	526	505	62	12	.75	150	185
BS EBS	300	310	483	465	388	388	83	102	165	314	372	582	317	373	578	485	75	12	.75	190	235
BS EBS	400	380	597	585	482	482	107	127	200	375	435	684	373	443	684	560	95	16	1.5	380	450
BS EBS	450	Square only	665	560	560	130	152	254	407	468	749	405	475	749	650	112	16	1.5	570	680	
BS EBS	600	550	780	850	720	720	140	152	254	558	621	985	558	626	985	825	150	20	3.0	910	1100

Materials of construction and/or alternative valve features may alter some of the stated dimensions. This information is therefore to be used for guidance only. Use certified drawings for planning-in. These will be issued against an order. These valves must not be considered as load-bearing without prior consultation.

# Typical Rotor Configurations

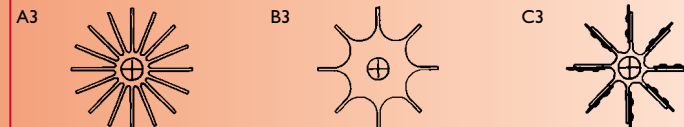
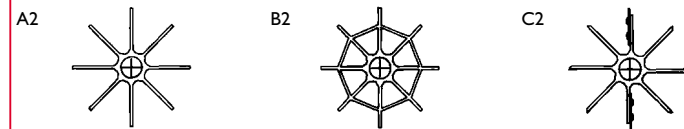
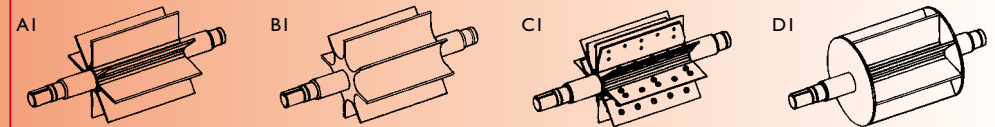

- A1: Open Fixed vane } basic rotor
- A2: Open Fixed vane }
- A3: Extra vanes for higher sealing efficiency and/or smooth discharge
- B1: Open fixed vane - scalloped
- B2: Reduced capacity
- B3: Scalloped for sticky materials
- C1: Open vane - replaceable blades
- C2: Chamfered fixed vane with two scraper blades
- C3: Open vane - replaceable blades
- D1: Closed vane - options as open vane

THE ABOVE ILLUSTRATIONS REPRESENT THE MORE COMMON ROTOR TYPES IN USE. OTHERS ARE AVAILABLE TOGETHER WITH A WIDE RANGE OF MATERIALS OF CONSTRUCTION AND COATINGS