

Key Features

- Safe and easy cleaning of internal components and surfaces
- Construction features available to meet stringent hygiene requirements
- Wide range of rotor shaft seals available
- USDA (FDA approved)
- Explosion-proof and flame-containment design
- Close operating clearances for optimum efficiency
- Rotor and End Covers removable separately
- Direct (standard) or indirect drive systems

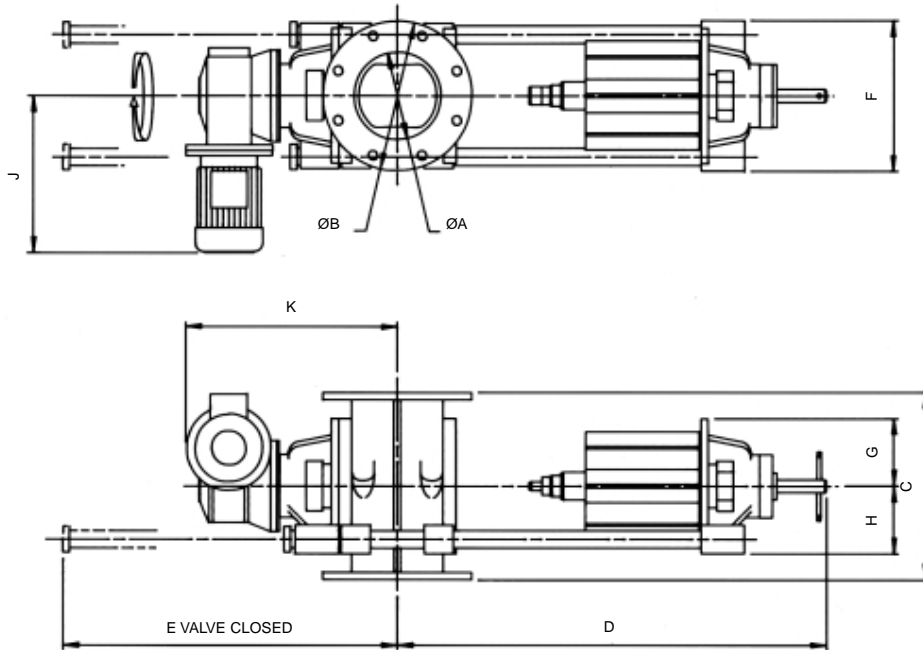

	A	B	C	D	E	F	G	H	J	K
FCT125	125	254	310	802	660	252	100	100	315	380
FCT150	150	280	360	860	700	304	125	125	352	425
FCT200	200	343	430	1170	1000	350	155	155	360	490
FCT250	250	406	490	1150	982	400	180	180	406	540
FCT300	300	483	600	1245	1050	464	200	200	459	596

This information is for guidance only. **USE ONLY CERTIFIED DRAWINGS FOR PLANNING-IN**
 These valves must not be considered as load-bearing without prior consultation.

ROTAVAL

Keeping the World's Industries Solidly in control



'Fast-Clean' Rotary Valves

Inlet sizes 125mm-300mm
 Capacities up to 47m³/hour



ROTAVAL

Przedstawicielstwo w Polsce - PROORGANIKA S.A.

01-755 Warszawa, ul. Krasińskiego 69

Tel: +48 (022) 3260350, Fax: +48 (022) 3260351

Email: proorganika@proorganika.com.pl, www.proorganika.com.pl

